

ETUDE DETAIL 2

Ech 1:5

le CV de pignon n'est pas représenté et son étude n'est pas demandée

vue en élévation

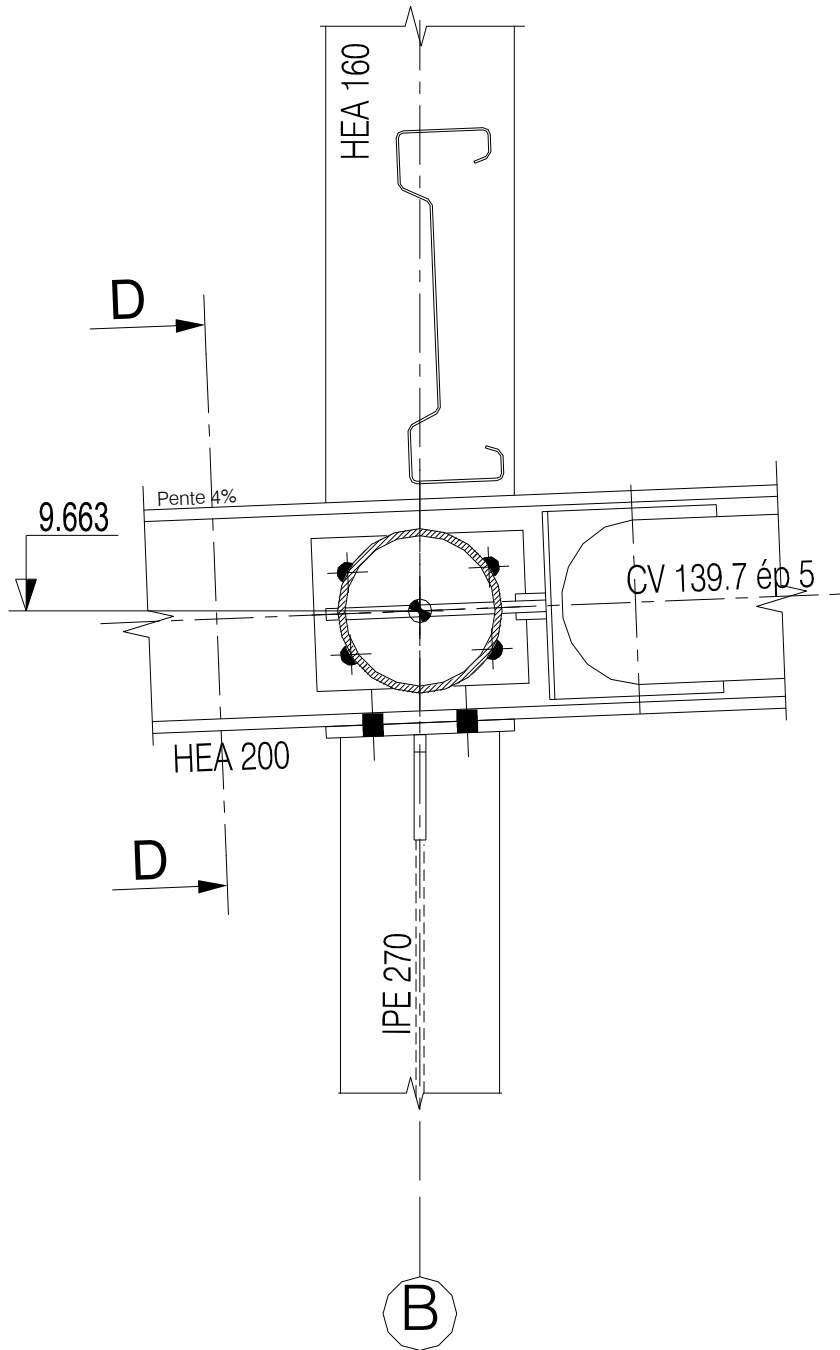

D-D

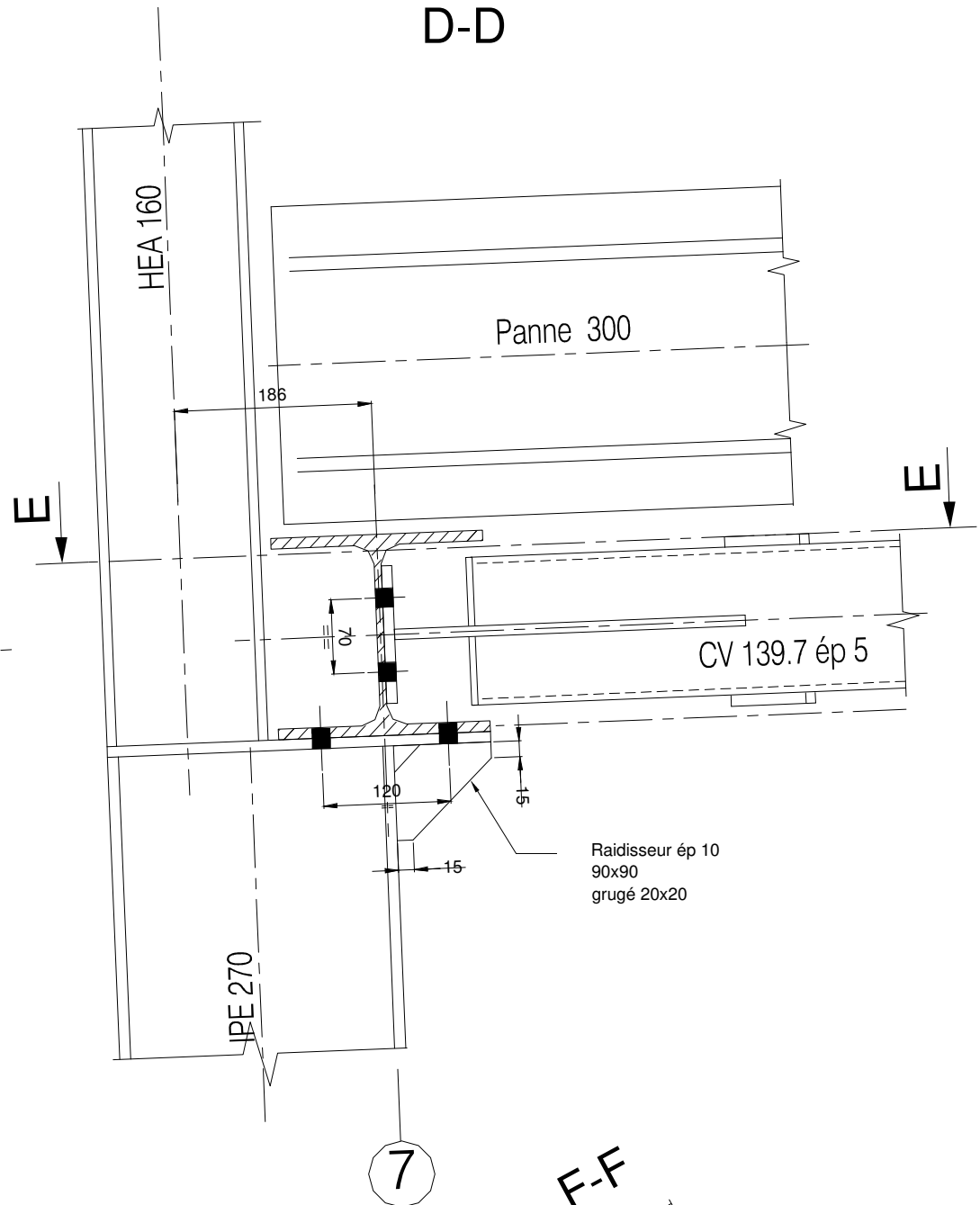

2 BI H M18-50 cl 6.8
Chape ép 6

F-F

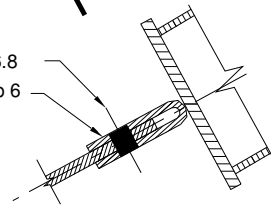

E-E

